



Custom 3-Point Seatbelt Installation Guide for: 1963-67 Corvette



Note: The information enclosed in this installation guide is to be used as merely an outline to assist you during the process of installation. This guide does not cover every installation possibility, vehicle, or every aspect of the installation process. Seatbelt Solutions assumes no responsibility for a proper or improper installation. Every attempt has been made to make this installation guide as informative as possible, and therefore may be updated from time to time. Please check our website for the latest update.

'63 - '74 Corvette Seatbelt Hardware Install Kit

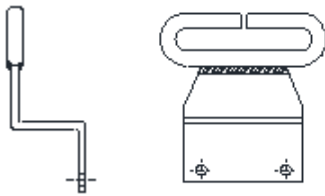

Shoulder guide assembly
Qty included: (2) Pcs
63-67



.9" Diameter
Washer w .5" hole
Qty included: (10) Pcs

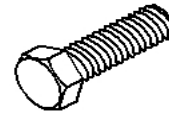

1.75" (1/2")
Hex
Shoulder Anchor Bolt
Qty included: (6) Pcs



Small screw
Qty included: (4) Pcs

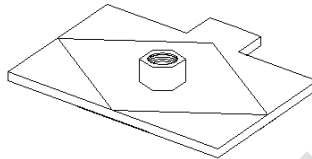

Plate with 1 welded nut
Qty included: (2) Pcs
LATE 67-74

NOTE: THESE PARTS MAY NOT BE NEEDED IN SOME CARS.

Note, the installation hardware above has been put together to cover as many variations of the '63-'67 Corvette as possible. In many instances, if your vehicle has existing anchor points installed you may not need some of this hardware. Please look over the installation guide for your type of vehicle, feel free to contact us for any questions you have.

Note: The information throughout this guide regarding installation is to be used ONLY as a guideline for installing anchor points in vehicles that are not equipped with anchor points. The installation steps in this manual should be performed by professional installers to ensure that the installation is as safe as possible.

Custom Installation guidelines:

Thank you for your purchase of this Seatbelt Solutions seatbelt product. Your Seatbelt product has been rigorously tested to meet or exceed Federal Motor Vehicle Safety Standards (FMVSS) #209, #302.

Where to Install Anchor Points:

Determine if your installation is a proper fit (no original seatbelts installed) or if you will be replacing existing 2 point belts and can use some of the existing anchor points. (Note: it is important that wherever you can, to use the factory anchor points, if it is determined that you must make your own anchor points, be sure to check behind or below where you will be drilling for adequate clearance for the bolt and reinforcement plate). **IMPORTANT:** When drilling, be careful to not accidentally drill into fuel lines, exhaust system, gas tank, brake lines, etc. If you have any question that the area you want to anchor to is weak, rusty, or otherwise not suitable, do not use it! The optional hardware kit does include some metal anchors for reinforcement purposes, it would be wise to reinforce an anchor point to insure the safety of you and your passengers.

Front (Driver & Passenger) Installation guide for 63-67 Corvette Coupe and Convertible.

1. Remove original seatbelts. Be sure to save the mounting bolts and other hardware.

1.

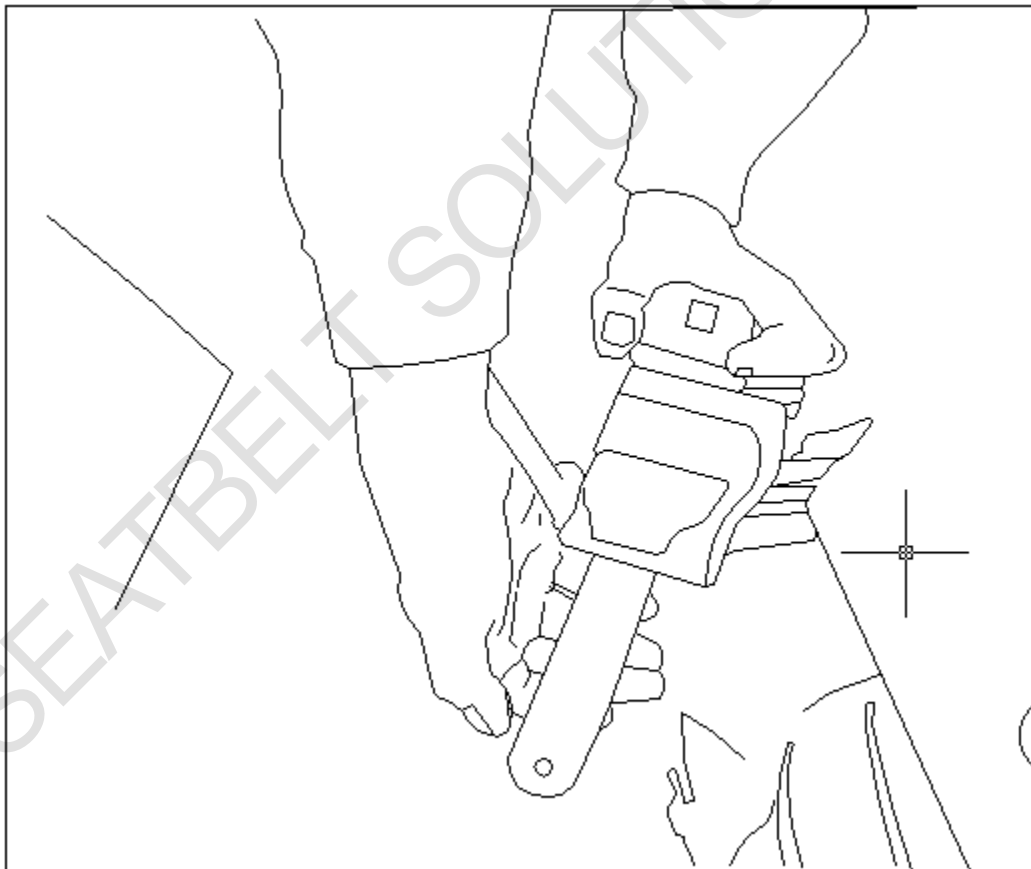

LATE 66-67 SEATBELT

Note: The original hardware will be used to mount the new belts.

Front (Driver & Passenger) Installation guide for 63-67 Corvette Coupe and Convertible.

2. Locate the rear seat panel. Remove the two screws holding the panel, and the seat lock panel. Carefully remove the panel to expose the mounting area for the web guide. See the illustrations below.

2.

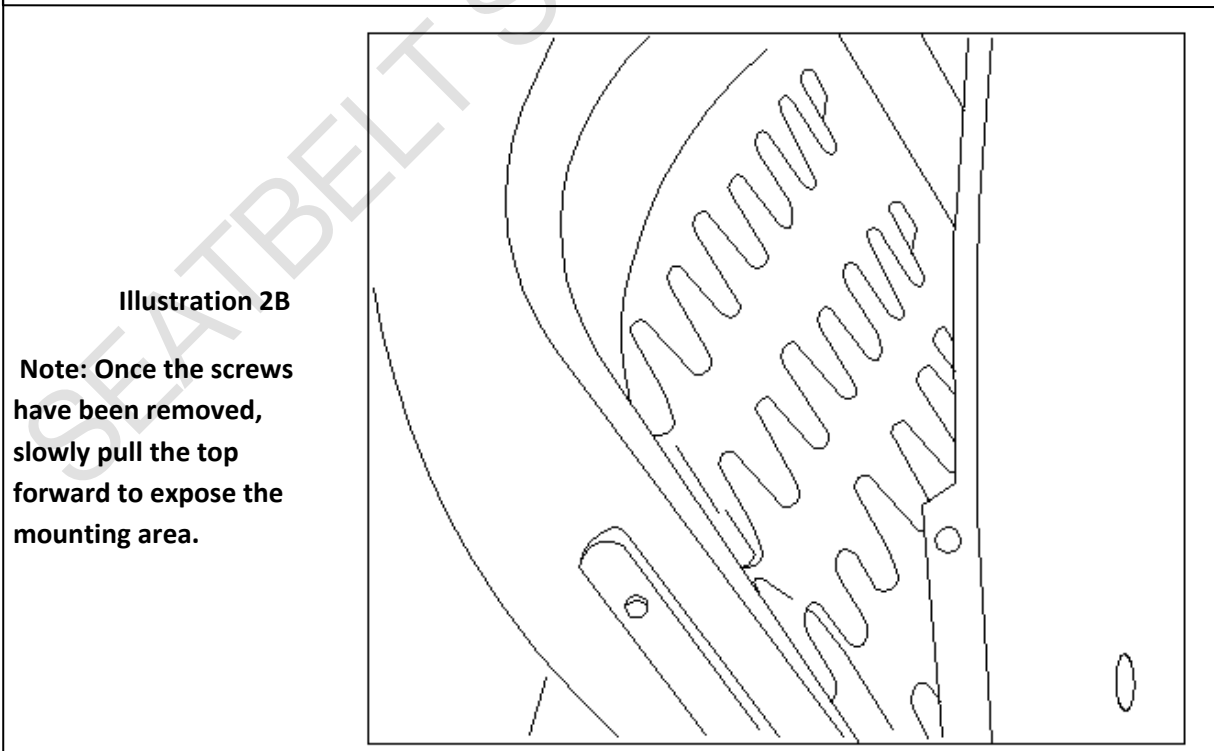
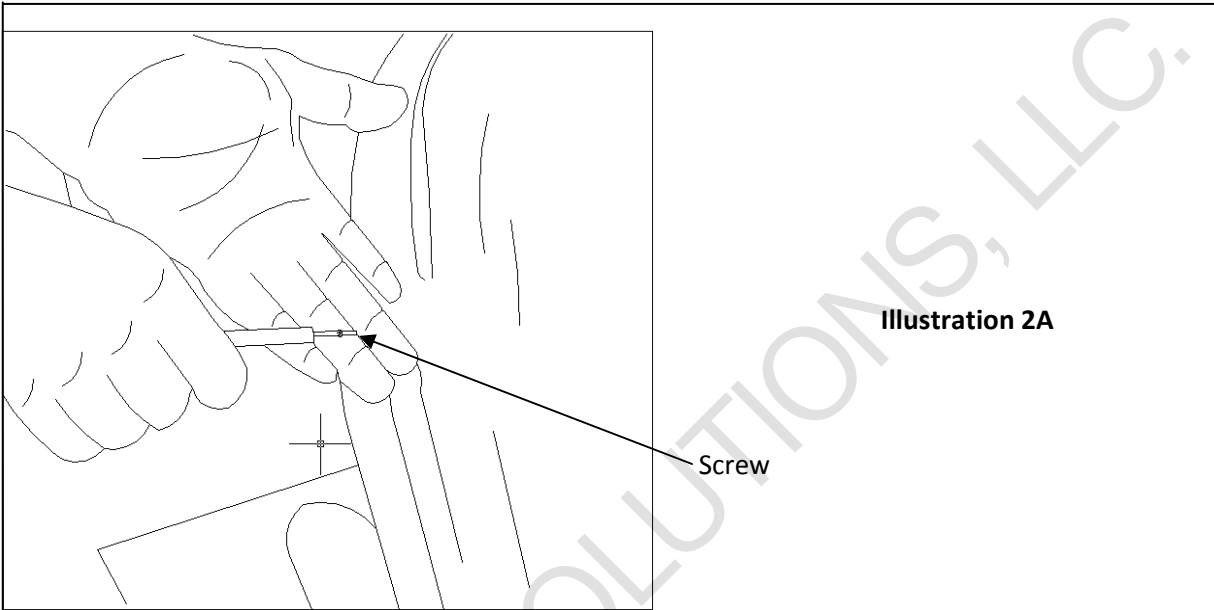

Front (Driver & Passenger) Installation guide for 63-67 Corvette Coupe and Convertible.

3. Using illustration 3A Locate the drill points for the seat belt guide. Once you have determined the drill points mark the holes using the openings in the seatbelt guide. Using a hobby knife or a similar cutting tool make a small hole in the center of the mark you made for the holes in the drill guide. This will help to serve as a guide for the screws. The hole made with the hobby knife should be smaller than the diameter of the screw. Once the guide is installed, press the seat back and secure using screws.

3.

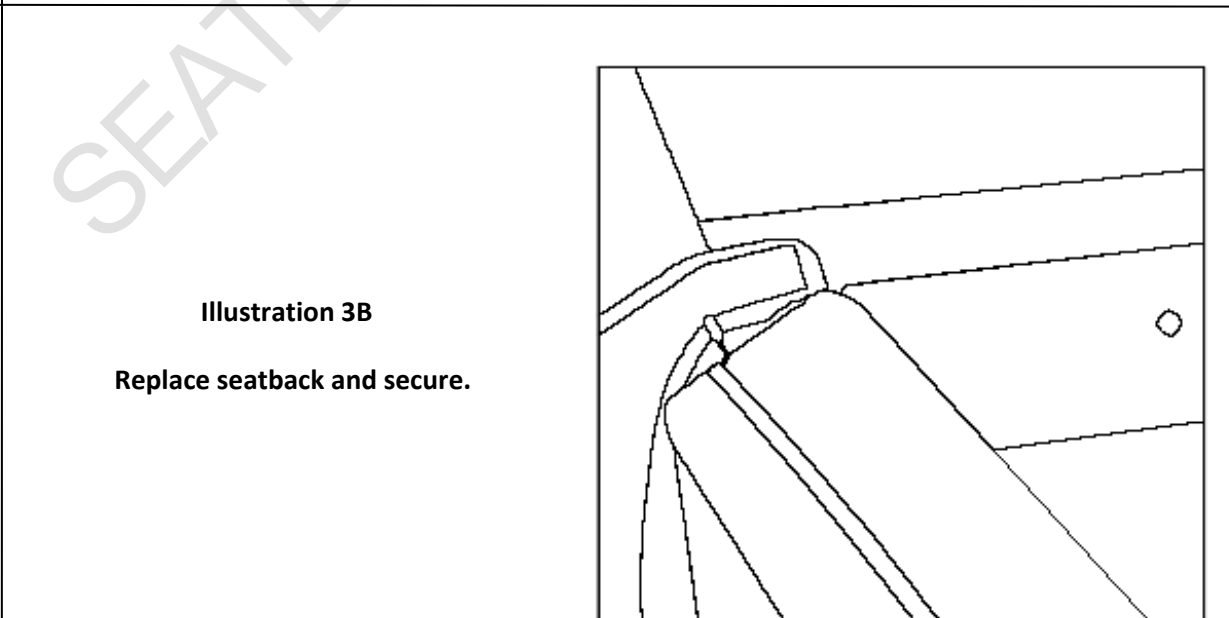
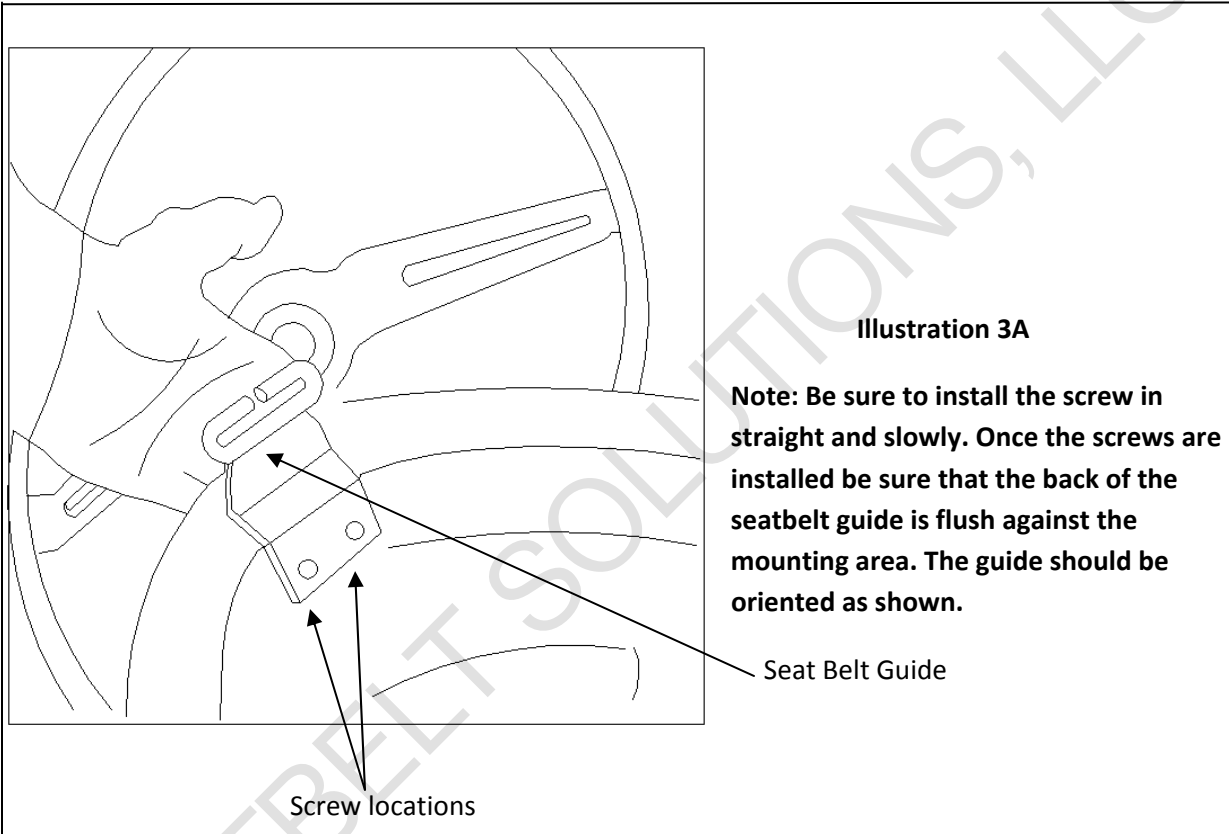

Front (Driver & Passenger) Installation guide for 63-67 Corvette Coupe and Convertible.

4. Measure 5 inches from the rear of the cover as shown in Illustration 4A, search for original plug in body. If plug is not present, mark this spot for drilling. Before drilling, be sure to make a cut in the rug. Using a ½ inch drill bit make your hole.

4.

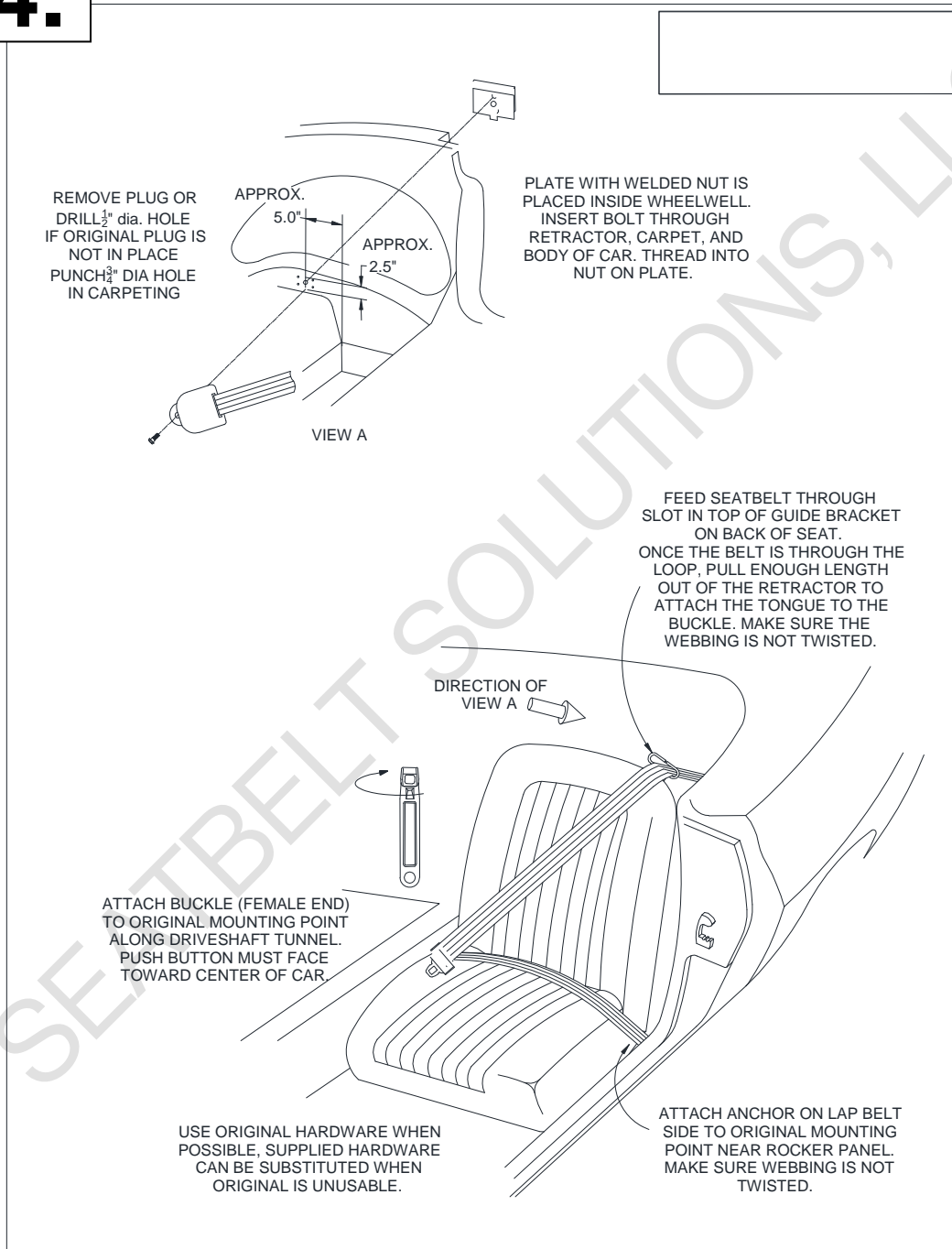

1963-1967 ILLUSTRATION 4A

Front (Driver & Passenger) Installation guide for 63-67 Corvette Coupe and Convertible.

5. Take the H.D. Steel plate with the welded nut provided and place it as shown in illustration 4A. Take the retractor and with the bolts provided insert the bolt thru the wheel well as shown. Tighten as necessary.

5.

Note: Illustration 4A shows the retractor with bolt and the welded nut steel plate. 5A shows the outer wheel well side 5B shows the top view of the installed retractor.

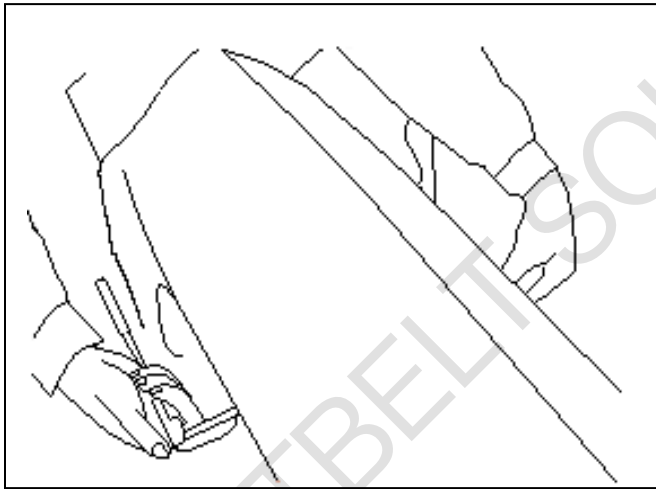

Illustration 5A

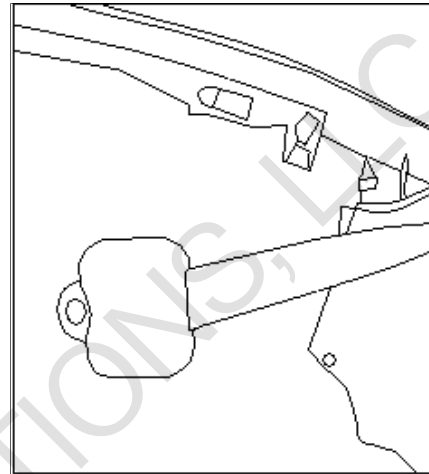

Illustration 5B

Front (Driver & Passenger) Installation guide for 63-67 Corvette Coupe and Convertible.

6. Take the webbing and using the opening on the web guide, slide the belt thru the top of the web guide as seen in Illustration 6A. Once the belt is thru the loop, pull the belt thru till you have a sufficient length to attach the belt to the original mount. Attach the belt to the original mount and mount the belt latch end to the original mount using the bolt and nut. Pull the tongue down to latch and make sure that the webbing is not being twisted along the upper or lower restraint.

6.

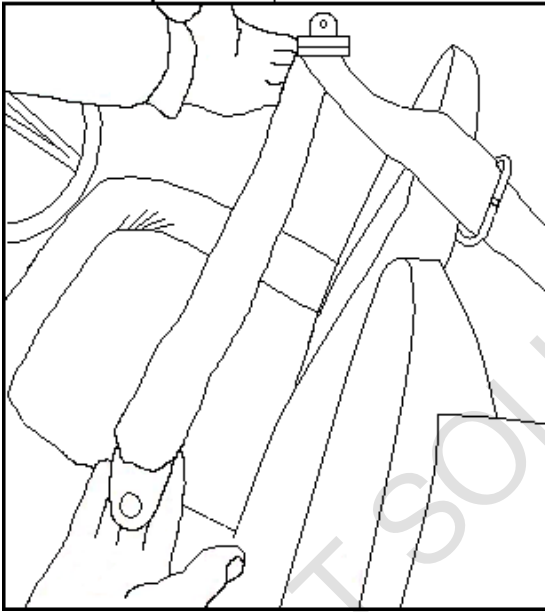
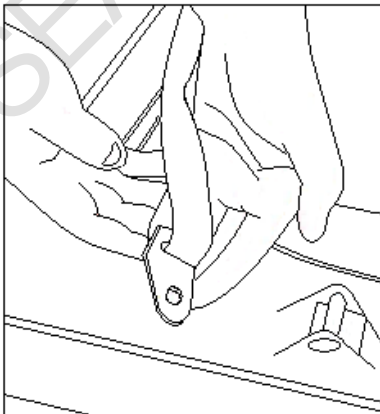

Illustration 6A

Illustration 6B



Note: pull the tongue to your latch to complete the three point assembly. make sure the webbing is moving freely from the retractor thru the guide.

Illustration 6C

