

Seatbelt Solutions

"Your Affordable

Solution To Safety"

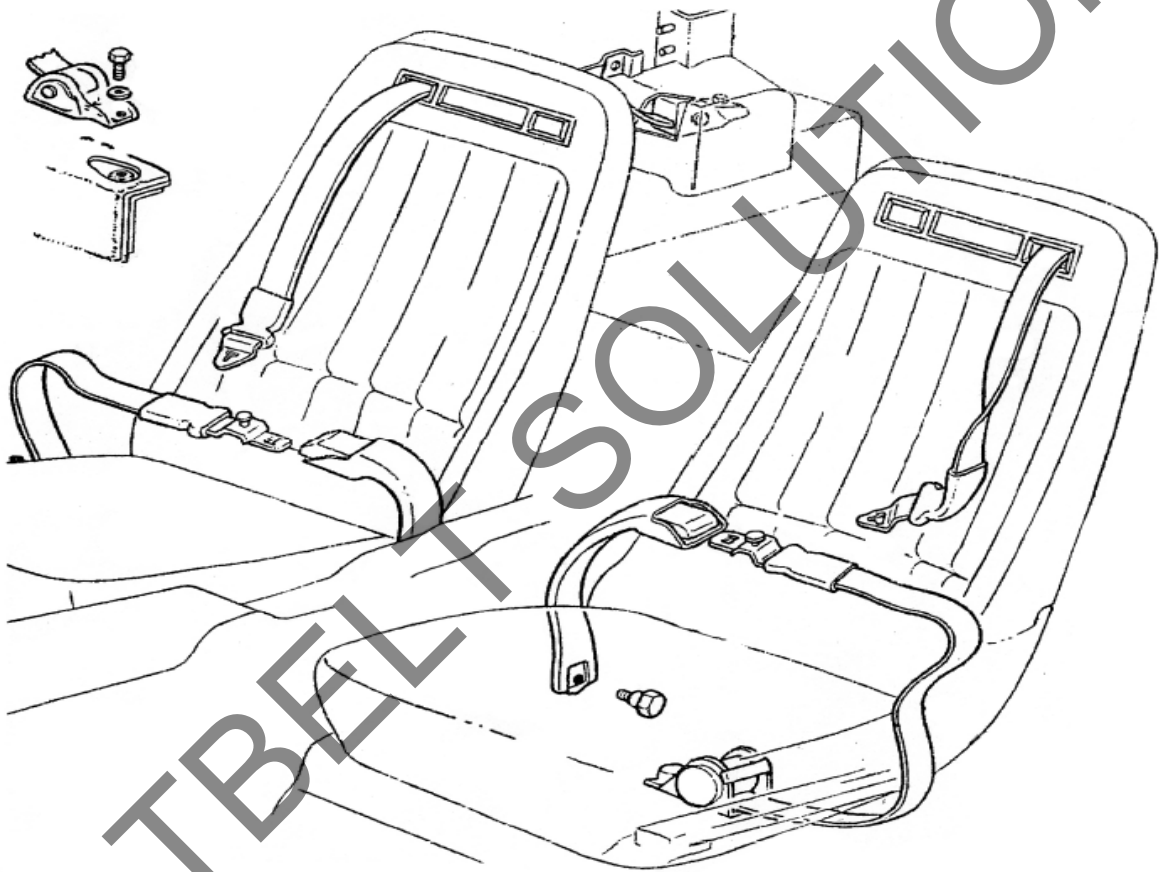

72-73 Dual Corvette Coupe

Technical Support Call 866-904-2358

15835 Corporate Road North

Jupiter, FL 33478

OVER ----->

Seatbelt Solutions

CORVETTE

1970-1977 Shoulder retractor lock removal

The Shoulder belt retractors we use for 1970-1977 Corvettes are a position sensitive design, meaning they will only operate when installed in the factory location laying flat. Your New seatbelts should have enough webbing material outside of the retractor to allow for installation. Follow this procedure to remove the retractor lock once the installation is completed to allow free operation of the shoulder retractors.

1970-1973 Coupe and Convertible
1974-1975 Convertible



Remove Plastic cover to access mounting hole and plastic lock

Remove Plastic Lock after installation is complete

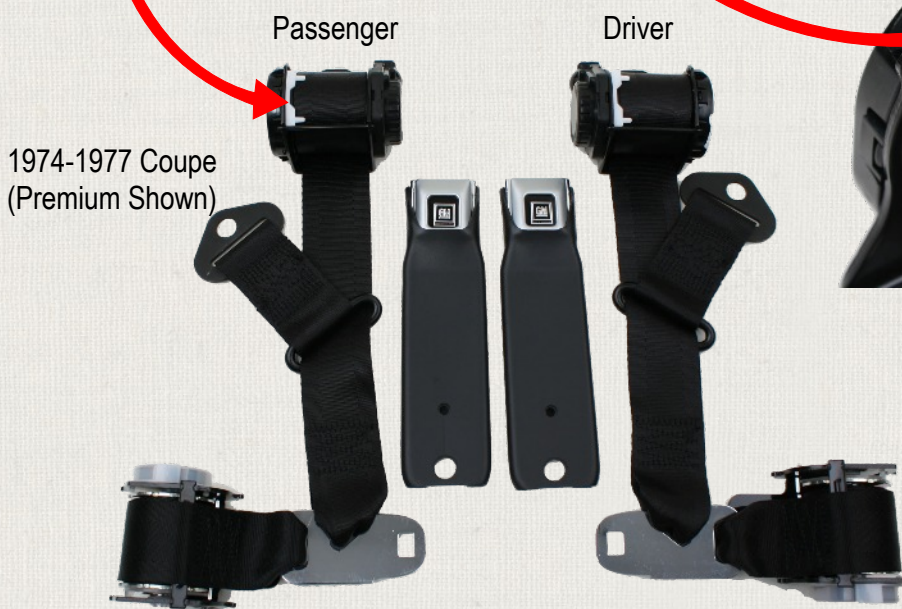

Passenger

Driver

1974-1977 Coupe
(Premium Shown)



All Retractors are aftermarket units that will differ in appearance from factory GM retractors but are still direct fit.

SPECIAL NOTE:

Some Corvettes have a dowel pin located close to the mounting hole for the shoulder retractors. The retractors used are an aftermarket design therefore provisions for this dowel pin do not exist. You will need to remove the pin from your Vehicle to allow the retractor to lay perfectly flat for correct operation.



With Domestic and Foreign Parts

15835 Corporate Road N Jupiter, Fl. 33478

866-904-BELT (2358)

Fax (561) 747-7529

orders@seatbeltsolutions.com